

100% SMART ex works

Every S.CF LIGHT 40/45 container chassis has the TrailerConnect® telematics system on board



All S.CF container chassis are equipped with TrailerConnect® telematics as standard. You have immediate access to the telematics portal and the beSmart and beUpToDate apps from Schmitz Cargobull.

Your advantages are:

- **Efficient fleet management** with real-time information on the current status of the fleet.
- **Intelligent scheduling** that optimises routes and on-time delivery while avoiding empty runs.
- **Higher trailer availability** - proactive maintenance minimises downtimes and breakdowns.
- **Reduction in process costs** for trailer utilisation and personnel deployment.
- **Monitoring the tyre pressure** reduces fuel consumption, increases tyre mileage and reduces tyre damage due to wear.



SCHMITZ
CARGOBULL

The Trailer Company.

Everything from a single source

Premium-Services from Schmitz Cargobull



Container chassis S.CF LIGHT 40/45

Robust and payload-optimised for 40' and 45' containers

Benefits at a glance:

- Weight-optimised for 40' and 45' containers with a tunnel
- Easy handling with mechanical front extension
- New telescopic underride guard at the rear with simplified handling and no loose parts
- Galvanised chassis made of high-strength steel profiles for optimum protection against corrosion*
- TrailerConnect® tyre pressure monitoring system in accordance with ECE-141
- 100% SMART with telematics equipment ex works
- Innovative operating concept with simplified user guidance thanks to clear handling instructions on the vehicle, including operating videos via QR code
- Two pairs of ferry lashings for ferry transport and intermodal transport
- Optimised spare parts supply through the use of Schmitz Cargobull standard elements
- Durable and robust Schmitz Cargobull quality

S.CF-LIGHT-LIGHT-FLY-DEGB-10680-0424

* Option

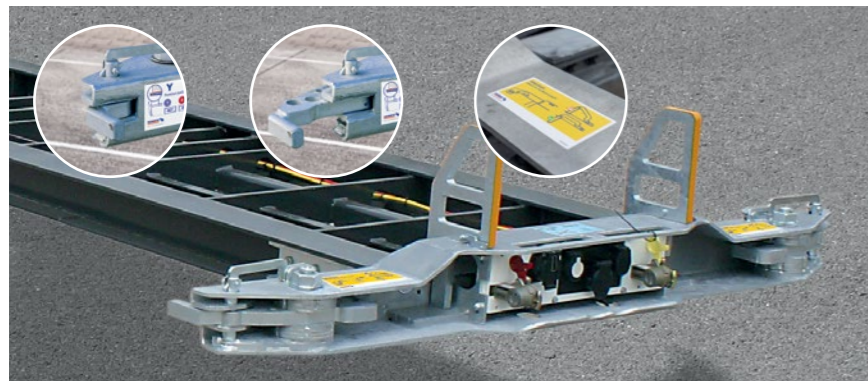

MULTI LOCK on the front beam in the locking positions for tunnel containers with angled corners and straight corners with positively guided plug-in lock.



Mechanical front extension for 45' containers is spring-mounted on rollers and easy and safe to handle.

Container chassis S.CF LIGHT 40/45

Container loading plan

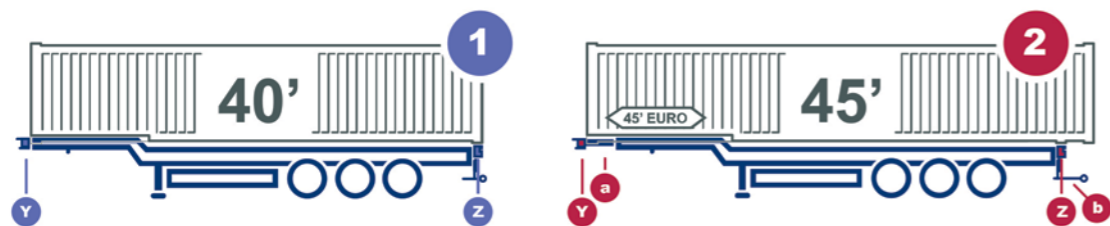

New: TrailerConnect® telematics equipment
with tyre pressure monitoring system ex works



S.CF LIGHT 40/45
in the video



Standard **TWIST LOCK** locking mechanism: retractable and with anti-rotation lock



New operating concept with loading plan and clear **function and warning notices on locks and extensions.**



New labelling on locks and extensions for reliable identification of the different loading positions, supported by a loading plan and operating videos via QR code.

Illustrations may contain optional equipment. * Option.



Easily replaceable container **guides for containers** on the front beam.



The semi-trailer container chassis can be equipped with **ferry lashings*** for use in ferry transport.



New design: **fold-out underride guard** for 45' containers is easier and safer to handle without loose parts that can get lost.

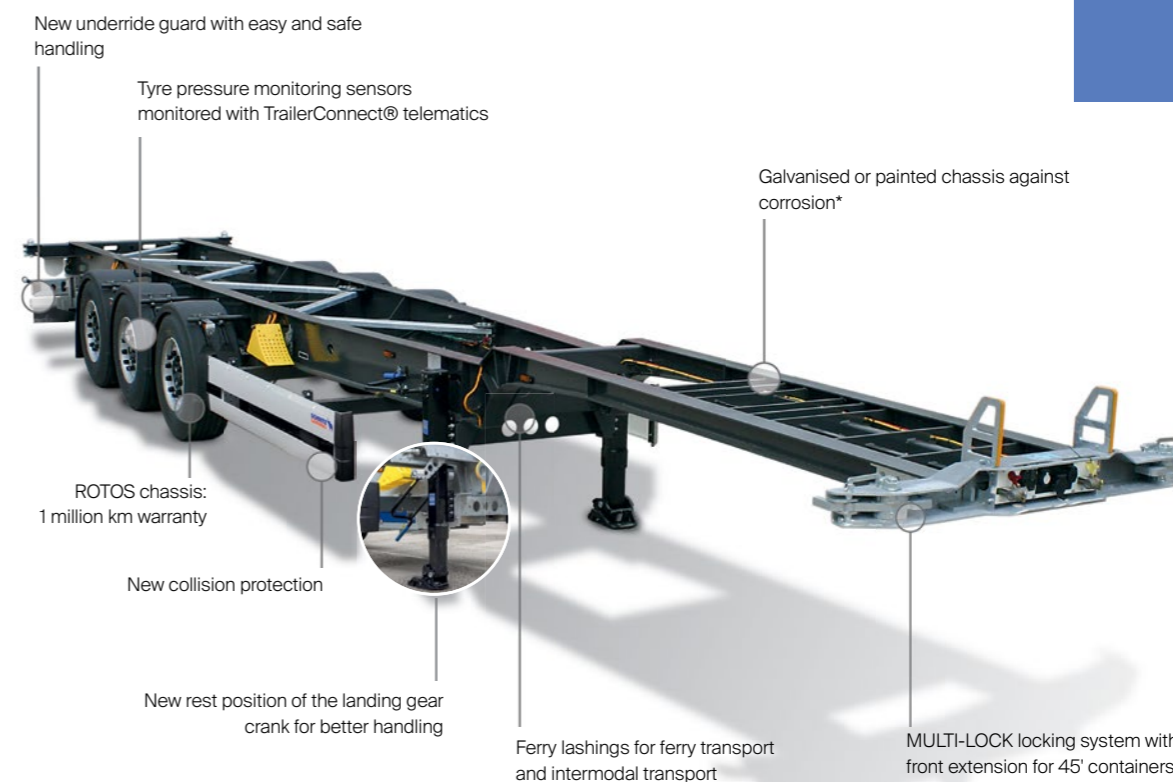

New side **collision protection** and fire **extinguisher*** on the support structure.



The sturdy **tool box*** next to the side collision guard stores all the necessary equipment safely and neatly.



The **lift axle*** as a starting aid extends the wheelbase and thus increases the pressure on the drive axle. Unloaded and in the lifted position, tyre wear is reduced.